

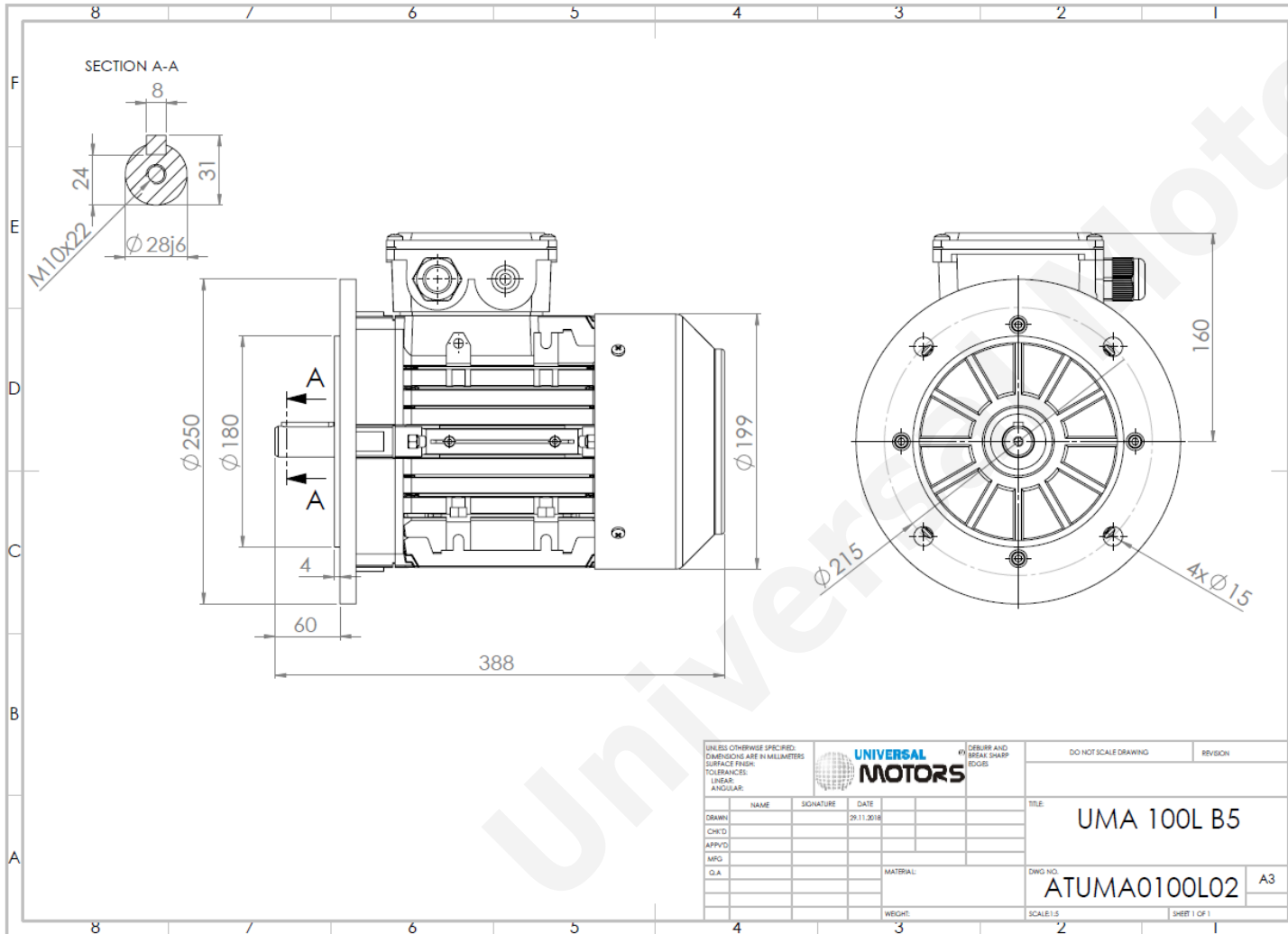

TECHNICAL DATA

Three Phase Electric Motors - Aluminum Frame
 UM2A 100L3-4
 4 kW / 5.5 Cv
 1440 RPM



Motor type:	UM2A 100L3-4
Output:	4 kW / 5.5 Cv
Speed (min ⁻¹):	1440 RPM
Frequency:	50 Hz
Voltage:	400 V
Current:	8.33 A
Power factor (Cos Ø):	0.80
Poles:	4
Insulation class:	F
Temperature rise Class:	B
Efficiency 50%:	86.5 %
Efficiency 75%:	87.4 %
Efficiency 100%:	86.6 %
Torque:	26.4 N.m
Tstarting/Tnominal:	2.8
Istarting/Inominal:	7.2
Tmaximum/Tnominal:	3.2
Noise:	65 Db(A)
Weight:	28.6 Kg
Brake AC:	AC5
Torque Brake DC:	32 N.m
Bearing DE:	6206 2Z
Bearing NDE:	6206 2Z
Torque Brake AC:	40 N.m
Brake DC:	REB-05-12

Regime - S1

Altitude - 1000m

Environment Temperature - 40°C

CONTACTS:

UNIVERSAL MOTORS Tel: +351 252 299 080
 Rua de São Brás,745 Fax: +351 252 299 089
 4480-782 VILA DO CONDE Mail: geral@universalmotors.pt

* References applied only in the UK